

Expanda Jigs may be supplied in various stages of assembly, from boxed pack through to fully assembled. Assembly is a fast and simple process with all equipment and tools enclosed. Keep these tools for ongoing use and adjustment as required.

Before starting assembly, please read all sections of this guide to understand how each part is assembled and operated, as several parts may look similar to other jigs, however have unique features/ adjustments to the Expanda Series. **Failure to follow these quick and simple assembly instructions will void warranty for any replacement/ exchange should damage occur during assembly.**

Unpacking

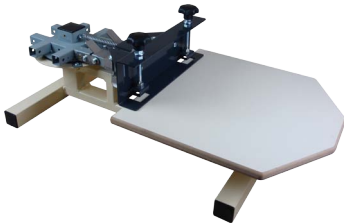

Contents: Expanda Single Colour Jig (SPJ-EX1)

- 1 x Base (with hub attachment bolts)
- 1 x T-shirt Board with Mounting Plate
- 1 x Hub with single Print Arm attached
- 1 x Print Head
- Plus Assembly Tools, IS44 Assembly Info. Sheet, IS30 Single Colour Registration Info. Sheet, IS34 Opaque Printing Info. Sheet



Contents: Expanda 4 Colour Jig (SPJ-EX4)

- 1 x Base (with hub attachment bolts)
- 1 x T-shirt Board with Mounting Plate
- 1 x Hub with four Print Arms attached
- 4 x Print Heads
- Plus Assembly Tools, IS44 Assembly Info. Sheet, IS30 Single Colour Registration Info. Sheet, IS31 Multiple Colour Registration Info. Sheet, IS34 Opaque Printing Info. Sheet

Check Pack Contents



Once unpacked, lay all parts out, check all items are supplied then proceed to Step 2 below. If unsure on part names, simply continue to read this sheet before checking, as each item is described in greater detail.

If you believe an item to be missing, damaged or an incorrect item is supplied, do not proceed to assemble the jig. Contact your place of purchase or the NEHOC Support Team on +612 9979 9700. All Expanda Jigs are covered by warranty, so check before proceeding as incorrect assembly will void warranty and any full system replacement.



Assembly

The supplied assembly tools are required for tightening/ loosening and attachment of parts. Where some parts have been pre-assembled, proceed to next step of the assembly process.

Understanding Part Names

Review the part names below as they are commonly referred to throughout the assembly instructions.

Part Names

- Single colour jig pictured

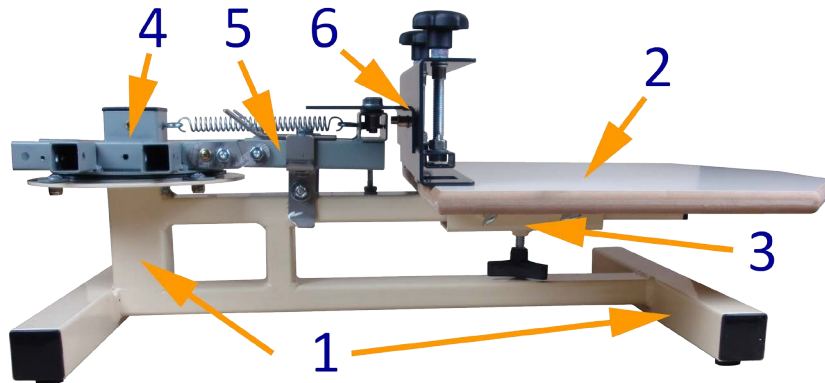

1. Jig Base
2. Palette, Printing Board, Platen, T-shirt Board or Jig Board (attaches to the Palette Attachment)
3. Part # SPJ-EXPA - Palette Attachment, Metal Palette Attachment (secured to the board, attaches to the Base)
4. Hub or Printing Hub (attaches to the Base)
5. Print Arm or Jig Arm (attaches to the Hub)
6. Print Head, Clamp or Frame Holder (attaches to the Print Arm)

The supplied assembly tools are required for tightening/ loosening and attachment of parts. Where some parts have been pre-assembled, proceed to next step of the assembly process.

Attach Printing Board to Base



Step 1

Expanda Jigs use a unique quick fix Metal Palette Attachment to mount a printing board to the base of the jig. This allows for multiple sized boards to be easily and quickly fitted, along with any custom boards or sizes.

The package contains a T-shirt board, pre-mounted with a Metal Palette Attachment to the base .

- Loosen the main attachment knob and both side adjustment screws
- Slide the top mounting on the Jig Base, through the Palette Attachment to slide and secure the board onto the jig
- For the remainder of the assembly process, slide the T-shirt board fully onto the jig, the board will stop at the Arm Height Adjustment Bolt
- Tighten the knob on the bottom of the board to secure

Attach Hub to Base



Step 2

Attach Hub onto the Base of the jig.

- Loosen and remove the 4 bolts from the Jig Base where the Hub will sit
- Place the Hub, pictured below, onto the Base and replace 4 bolts, finger tighten to secure
- Using supplied tools tighten Hub to secure firmly to the Jig Base

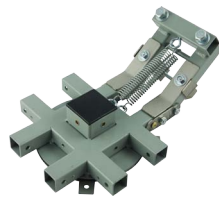

SPJ-EX1 Hub with single arm attachment

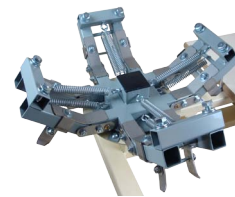

SPJ-EX4 Hub with 4 arms attached (secured to hub)

Where some parts have been pre-assembled, and/ or not required, proceed to next step of the assembly process.

Attach Print Head

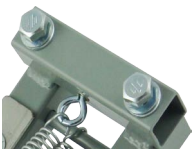

Step 3

A Print Head must now be attached to the Print Arm to complete the arm assembly. The Print Head is attached using two bolts located at the end of the Print Arm, pictured left. The bolts are pre assembled into the end of the arm upon shipment.

- Loosen the bolts 5-7mm using the supplied tool - do not completely remove from the assembly
 - Separate the washers and insert the Print Head between, with one washer and the bolt head on top of the metal sleeve, as pictured left.
 - Using supplied tool tighten the Print Head to secure - do not overtighten
- Repeat above process to attach all available Print Arms and Print Heads.



For single colour jigs a single print head/ arm combination are supplied. This can easily be expanded by adding additional print arms/ heads to increase the printing capacity of the jig.

See Page 4 for details in section 'Increase Your Colours - Adding Expanda Print Arms'

Important Note

The position of the Expanda Print Head is adjustable, allowing forwards/ backwards registration during either the registration or printing process.

It is recommended the position of the bolts be placed in the middle. This allows for maximum adjustment in both directions upon setup of the screens and for micro registration in both directions during printing if required. Where greater reach is required during registration (than the Print head allows) adjust the position of your Printing Board to bring it closer, then readjust the Print Head.

Arm Height Adjustment Bolt



Step 4

Using the Arm Height Adjustment Bolt is optional. The bolt may be removed for printing if not required, or when using the vertical adjustment screws in the Print Head assembly.

The purpose of the bolt is to elevate the Print Arm above the normal flat printing position - enabling off contact printing. Adjustment of the height can be performed both during initial registration and during printing if additional (or less) height is required.

Using this feature is much easier compared to the previous process of having to raise/ lower the entire screen using Plastic Height Adjusters within the Frame Clamp assembly.

Adjusting Arm Tension Springs

The tension of the arms is factory set, to return the arm to an upright position after printing, however you can easily adjust the tension to a softer/ harder feel.

- Remove the black cover from the Hub centre and detach the springs from the Hub Bolts
- Turn the Bolts to either tighten or loosen (reattach the springs to test)
- When required tension is reached, reattach the springs and replace the black cap to the Hub

After a short period of initial use (or when using heavy metal/wooden frames) tension springs will stretch and requiring tightening to maintain your preferred setting.



Expanda Jig Usage

The Expanda series is designed with all new functions to speed your printing, improve registration and save you valuable time. In addition to Information Sheet #25 'Screen Printing Technique', plus information Sheet #34 'Printing Opaque Fabric Inks', here's a few more Hints and tips on using your Expanda jig.

Apply Table Adhesive



Before using your jig for the first time, apply Table Adhesive to the board. Table Adhesive is a pressure sensitive glue that will hold your T-shirts, fabrics and other items still whilst printing.

- Stops movement of the item and eliminates bleeding/ blurring during printing
- Required for all off contact printing to hold your item flat and stop lifting

When applied correctly there is no glue or residue on your items. Being a water based product any excess is easily removed with a wet rag (or in the first wash).

Details: www.nehoc.com.au/go/htah

Registration Features

- T-shirt Board
- Print Head
- Frame Clamps



Expanda Jigs contain several registration features that can be used together, or individually, to obtain registration of your designs - both before and during printing.

The following information should be used in conjunction with Information Sheets #30 and #31 supplied with the Expanda Jig, or available online www.nehoc.com.au/training

Step 1

The first step is to place a copy of your design on the item to be printed, then place the item (with registered design attached) onto the T-shirt Board for printing (see separate Information Sheets #30 & #31 for full details of this process)

- On the T-shirt Board, loosen the main attachment knob and both side adjustment screws
- Slide the T-shirt Board into position and tighten the main attachment knob
- Tighten the side adjustment screws to eliminate all movement

Step 2

Insert your imaged screen into the Print Head and lower into place to gauge a more detailed view of your print location.

- Loosen the Frame Clamps, insert the frame to sit flat across the back of the print head and tighten the Frame Clamp's lightly
- Lower the Print Head over the item - the guides on the Print Arm will lock into place.
- Loosen the bolts on the Print Head, pictured left, and move into position. When in position so that the design is almost in the correct registration (forwards and backwards), tighten the bolts.

The registration does not have to be 100% accurate at this stage as micro registration can be performed using the Frame Clamps at the next stage.

Step 3

Complete registration by adjusting the frame using the Frame Clamps in the Print Head.

- With your board and arm in the right area, micro registration is now achieved by moving the frame within the Print Head, then clamping into place using the Frame Clamps.

Details on Colour Separations: www.nehoc.com.au/training/is/13

Details on Single Colour Registration: www.nehoc.com.au/training/is/30

Details on Multi-colour Registration: www.nehoc.com.au/training/is/31

Off Contact Printing

- Vertical Print Head registration
- Arm Height Adjustment Bolt



Expanda Jigs allow vertical registration and movement through two elevation methods - with both methods adjustable during printing.

The preferred method for elevation is using the Arm Height Adjustment Bolt (detailed on page 2) which is adjusted to lift/lower the Arm & Head assembly as a whole.

- Unscrew lower nut and adjust to correct height by rotating bolt. Re-tighten nut when in position

Secondary height registration is available using the two Vertical Registration Screws (pictured below left) in the Print Head.

- Unscrew using the tool provided and adjust to the required height then re-tighten

Arm Height Adjustment Bolt can be removed when not required for 'off contact' applications. The Print Head should be returned to original position after every job.



By elevating the screen above the item to be printed the screen has minimum contact with the item below and all the ink is printed = no blurring and maximum ink coverage.

- Used for Opaque, Metallic and Puff fabric inks, or synthetic materials with poor absorbency, and all metals, plastics, glass and other non-absorbent materials where the ink is printed on top of the item - then either absorbed, structurally bonds or etches as the ink cures

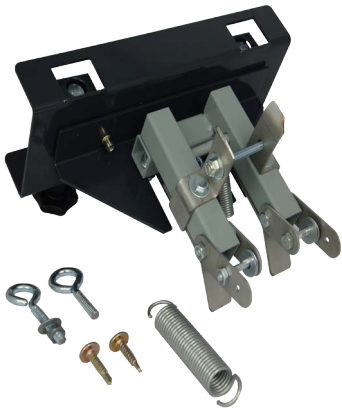

Increase Your Colours - Adding Expanda Print Arms

Adding an additional arm, or removing an arm, is a simple process using the unique Expanda Series arm design. Arms can be added at any time to a Single Colour Jig, or arms removed from Multiple Colour Jigs for storage/ transport.

Contents: Expanda Additional Arm (SPJ-EXARM)

- 1 x Print Head
- 1 x Print Arm
- 2 x Attachment Screws
- 1 x Attachment Bolt (short)
- 1 x Attachment Bolt with Nut (long)
- 2 x Attachment Springs

Additional Arms may be supplied in various stages of assembly, from completed units (pictured above left) to individual items requiring full assembly.



Step 1

Attach both bolts to the centre of the Hub, as pictured left.

- Remove the black cap from the centre of the Hub to expose the upper and lower holes
- Remove the nut from the longer bolt and insert into the lower hole
- Attach nut to the lower bolt and tighten to expose approx. 5mm - do not overtighten
- Screw the shorter bolt into the upper hole, no nut is required

If supplied assembled, you must remove the bolt, nut and washers (plus screw if fitted) from the end of the arm attachment, prior to fitting in Step 2 below.

Pictured right - End bolt, nut and washers supplied assembled must be removed.



Step 2

Attach Print Arm to the Hub.

- Place Arm against Hub and insert washers between the Hub and metal arm bracket
 - Slide the bolt through the metal attachment, washer, hub, washer and metal attachment
 - Lightly attach the nut - do not tighten/ allow movement - repeat on the other side
 - Insert the locating screw and tighten, repeat on other side
 - Screw the shorter bolt into the upper hole, no nut is required
- Pictured left the completed assembly, with bolt and washer positions, plus locating screw.



Step 3

Attach Tension Springs and adjust Tension Bolts.

- Attach lower spring to Print Head end of Arm, then to the Hub end - repeat for upper spring
- Spring tension will require adjustment to match other arm/s - see 'Adjusting Arm Tension Springs' on Page 2.*



Step 4

Attach Print Head - see Step 3 on page 2 for Print Head attachment details.

Speed Up Your Printing

Organise Your Workspace

The Expanda Jig automatically speeds printing by eliminating many of the manual steps of the printing process (lifting and placing the frame), with further gains achieved by:

1. Organising your workspace around the jig before you begin printing, by placing blank items on one side, stacking printed items on the other - without moving your position during printing. *This process will always be a personal matter. Adjust to meet your requirements or work area, based on a right handed printer.*
 - With your jig in the middle, just to the immediate right place scrap paper, ink/s (with ink knife inside) plus a bowl of water and soft cloth for any clean-up if required
 - Prepare all items to be printed and stack/ place them within reach to the left of the jig
 - Prepare an area to the right for printed items - stack able where possible, or hanging
2. Keep your squeegee inside the frame after printing - this eliminates mess, but more importantly saves valuable time as you eliminate placing and grabbing the squeegee from the bench
 - After a print, rest the squeegee standing up against the Print Head - this keeps colours separate and saves space on your bench
 - Re ink just before printing then return squeegee to frame for storage between prints

